

(No Model.)

J. BEVIER.

SPEED REGULATING DEVICE.

No. 338,916.

Patented Mar. 30, 1886.

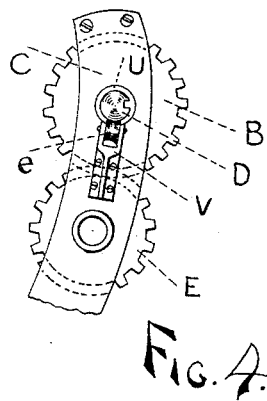
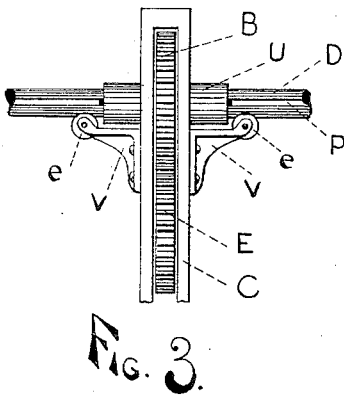
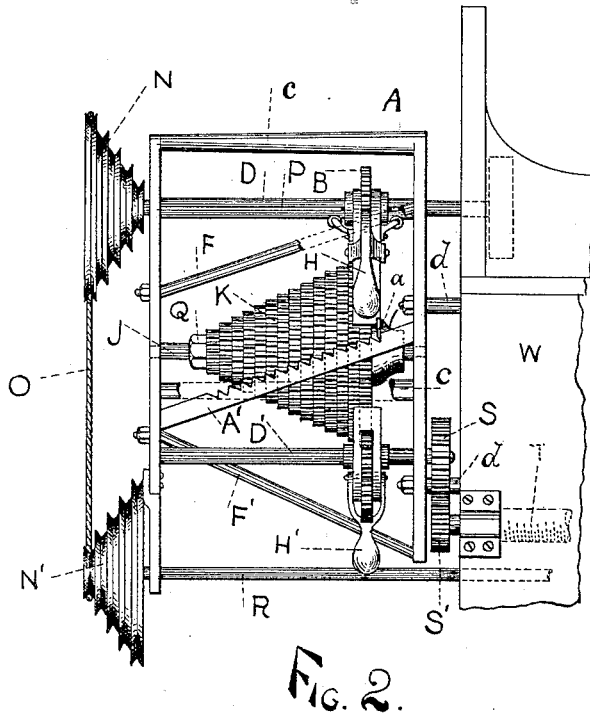
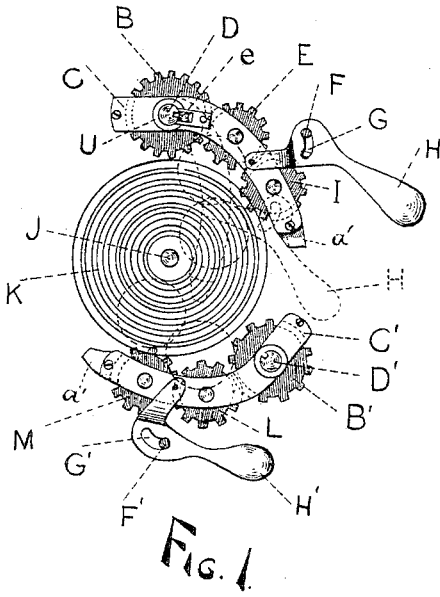

WITNESSES
George F. Conella,
Charles S. Hyer.

INVENTOR
James Bevier.
By *Amable*
Atty.

UNITED STATES PATENT OFFICE.

JAMES BEVIER, OF PETOSKEY, MICH., ASSIGNOR OF TWO-THIRDS TO CHRISTOPHER F. HANKEY AND ROLLIN C. DART, BOTH OF SAME PLACE.

SPEED-REGULATING DEVICE.

SPECIFICATION forming part of Letters Patent No. 338,916, dated March 30, 1886.

Application filed July 11, 1885. Serial No. 171,394. (No model.)

To all whom it may concern:

Be it known that I, JAMES BEVIER, a citizen of the United States, residing at Petoskey, in the county of Emmett and State of Michigan, have invented certain new and useful Improvements in Speed-Regulating Devices, of which the following is a specification, reference being had therein to the accompanying drawings.

This invention relates to speed-regulating devices; and the novelty consists in the construction, arrangement, and adaptation of parts, as will be more fully hereinafter set forth, and specifically pointed out in the claims.

For convenience of description, and to apply the invention to a known art, I will describe the same in relation to or as an attachment to a lathe; but it will be understood that the essential features of the invention will serve with advantage in other relations and combinations.

The object of my invention is to provide for multiple adjustments of speed from a given source, and to effect the change from one rate of speed to another without changing the mechanisms employed.

To readily and accurately vary the feed of various machines is a desideratum. In lathes, particularly, a very nice adjustment of the feed is frequently required, and it is desirable—as, for instance, in screw-cutting lathes—that small fractions, as hundredths of an inch, may be accurately determined and quickly adjusted. I provide for receiving motion from a given shaft and for transmitting it to a cone-gear.

For this step or part of the process embodied in the machine I employ a train of gear journaled in a frame, having the power-shaft for a pivot, the gear upon one end being hung upon and made to revolve with the power-shaft, but having longitudinal movement thereon. The motion imparted to this end gear is transmitted through the train and from the last gear therein to the cone. The train is movable, and may be thrown into mesh with either of the gears in the cone. The cone is made up of a series of different-sized gears secured rigidly together, and the larger the gear used in the cone as a medium for receiving the motion the more will the speed be reduced, and vice versa. From the opposite

side of this cone, by a similarly-movable train of gear, I transmit the motion to a transmitting-shaft, and from thence by gear and pinion to a threaded rod, which, for purposes of this description, will be called the "feed-shaft," upon which may be hung a carriage or other suitable device, as the purpose of the machine used may suggest. It will be observed that I employ the cone as a means of adjusting or changing the motion or speed once in receiving the motion and again in transmitting the motion, and that the various adjustments may be made with the same set of mechanism. With a cone of nineteen gear-wheels three hundred and sixty-one (361) different changes can be made without necessitating the interchanging of any of the parts of the device.

I provide convenient means for locking the movable trains at any desired point and for insuring ready and easy change from one adjustment to another.

I provide means for transferring motion from the same power-shaft to a rod arranged in juxtaposition to the point to which the motion through the cone is carried, and for changing the motion of said rod at will.

The invention is fully illustrated in the accompanying drawings, which form a part of this specification, and in which—

Figure 1 is a transverse section showing the relation of the cone to the transmitting-trains. Fig. 2 is a top plan view. Figs. 3 and 4 are detail views.

Referring to the drawings, A designates a supporting-frame secured by bracket *d* to the end of the lathe-frame W. The frame serves to support the working parts of the device, and, with its attachments, may be of any preferred and suitable construction.

D designates the power-shaft, having a groove, P, to which shaft is keyed the hub V of the gear B, which gear, while it has free longitudinal movement on the shaft D, is forced, by reason of its key-and-groove connection, to revolve with said shaft.

Centered upon the hub V is a frame, C, which is curved and has journal-bearings for an idle-gear, E, and a transmitting-gear, I. The frame C is movable with the hub V for a center, and is of such construction as to allow

its transmitting-gear I to be thrown into mesh with either of the series of gears of different sizes, held rigidly together on a shaft, J, having a collar, *a*, by a nut, Q, and constituting a cone gear, K, as shown. By moving the frame and its carried gears along the power-shaft the transmitting-pulley I may be made to mesh with either of the gears which constitute the cone, and the motion may by this means be increased or diminished at will.

Upon the side of the cone opposite the power-shaft is journaled in the frame A a transmitting-shaft, D', to which by similar key and groove is hung a gear, B', upon the hub of which is centered a frame, C', similar in construction and purpose to the curved frame C, and it carries an idle-gear, L, and a transmitting-gear, M. As this frame C', with its carried gears, may be readily moved along the shaft D', the gear M may be thrown into mesh with either of the cone-gears to vary the speed at will as it is being imparted to the transmitting-shaft D', thus obtaining two distinct series of adjustments by means of the cone-gear. The multiplicity of these adjustments will be appreciated when it is considered that when the transmitting-gear I is in mesh with either of the cone-gears a change of motion may be effected by changing the transmitting-gear M from one to another of said cone-gears, which equals a number of adjustments corresponding to the number of gears in the cone multiplied by itself.

The shaft D', by a pinion, S, is geared to a screw-shaft, T, carrying a pinion, S', and this shaft T may be used to operate a work-holding carriage or other suitable feeding device.

The principle of this part of this invention will be fully understood from the foregoing description, but I provide details of construction which materially assist in the convenient operation of the device.

In order to facilitate the movement of the frames C or C' along their respective shafts, I arrange upon either side of each frame a bracket, *v*, in which is journaled a riding-pulley, *e*.

To quickly throw either frame into or out of position to have its transmitting-gear mesh properly, I provide each frame with a handle-lever, as H or H', pivoted to its respective frame, and these levers have curved slots G G', which receive rods F F', secured to the frame A and held in such position as to correspond approximately with the incline of the cone. By throwing the handle-lever in one direction the transmitting-gear of the frame may be thrown squarely into mesh with either of the cone-gears, and by a reverse movement as readily thrown out of gear.

To hold the frames firmly with their gears into engagement with the cone, and to provide against lateral displacement of the meshed gears, I provide each frame with a locking-lug, *a'*, which engages a recess in an inclined guide, A'. Any other suitable locking device which will serve the purpose may be used.

For many purposes it is desirable to have a main or auxiliary operating-tool in juxtaposition to the feed-shaft T or its carriage. I provide for such tool and for operating it by the same power which impels the feed.

Upon the end of the power-shaft D is rigidly secured a cone-pulley, N, and a belt, O, connects this pulley to a similar cone-pulley, N', arranged reversely. The shaft R of the latter cone-pulley is carried parallel to the shaft D', and in proper juxtaposition to the feed-shaft T. The motion from the main shaft D in its transmission to this shaft R may be adjusted at will by changing the belt O, and any proper tool or other device may be carried by this latter shaft.

In details of construction modifications may be made within wide limits without departing from the principle or sacrificing the advantages of the invention.

The device may be applied to any machine other than a lathe in which two different speeds are desired, each variously adjustable with relation to the other.

I deem it important that I obtain a multiplicity of adjustments of speed without interchanging any of the operating mechanism, and that the cone is a means of adjustment arranged between independent movable trains of gear.

What I claim as new is—

1. In a device for regulating speed, a gear-cone arranged between two movable trains of gear, a power-shaft connected with one of said trains, and provisions for throwing either train into or out of gear with either of the cone-gears at will, as set forth.

2. In a device for regulating speed, a power-shaft, a train of gear revolving with said shaft and having longitudinal movement thereon, and a gear-cone arranged to be connected to the power-train through either of its gears at will, as set forth.

3. The combination, with a power-shaft, of two operating-shafts, as T R, and independent trains of speed-adjusting mechanism, one connecting each operating-shaft with the power-shaft, as set forth.

4. The combination, with the power-shaft and transmitting-shaft D', of the movable trains of gear, the cone K, screw or feed shaft T, and connections, as set forth.

5. The combination, with the grooved power-shaft and cone-gear K, of the frame C, the gear B, key-seated on said shaft, the transmitting-gear I, and means, as H, for throwing the latter into or out of engagement with the cone, as set forth.

6. The combination, with the power-shaft D P and gear B, having hub V, key-seated on said shaft, and having longitudinal movement thereon, of the frame C, centered on said hub, the handle H, and gear-cone, as set forth.

7. The combination, with the shaft D, frame C, having lug *a'*, and the gears B E I, as described, of the guide A', rollers *e*, and cone K, as and for the purposes set forth.

8. The combination, with the frames C C', having lug a', and handles H H', with curved slots G G', of the cone K, guide A, and inclined rods F, as and for the purposes set forth.

5 9. The combination, with the shafts D and D' and the feed-shaft T, of the cone K, the frames C and C', the independent trains, each having a gear, B or B', key-seated on its respective shaft, and a transmitting-gear, I or M,
10 arranged to be thrown into or out of mesh with either of the cone-gears, as set forth.

10. The combination, with the power-shaft D, feed-shaft T, the cone and connecting mechanism, as described, of the cone-pulleys N and N', belt O, and shaft R, as and for the purposes set forth. 15

In testimony whereof I affix my signature in presence of two witnesses.

JAMES BEVIER.

Witnesses:

CLAY E. CALL,

DOUGAL MCKENZIE.